

# MAMBA



3100



8960

## Dimensions and Performances

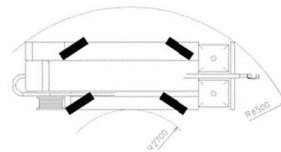
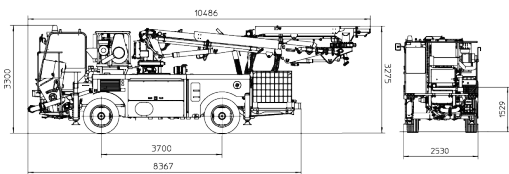
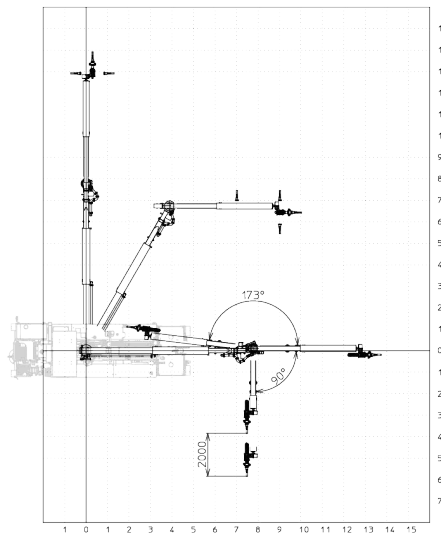
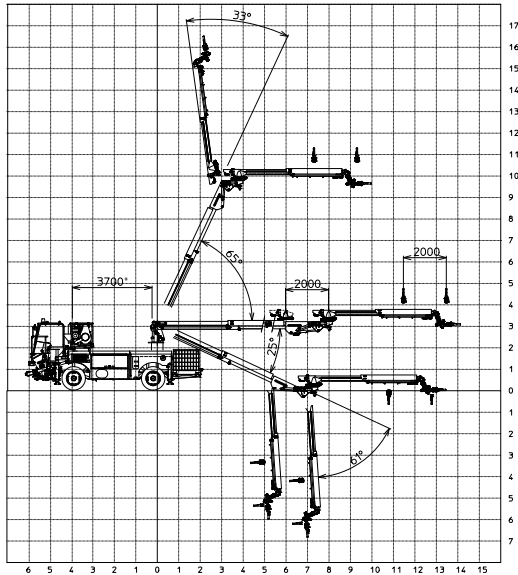



# MAMBA

## Characteristics

### Diesel engine

- TCD3.6Lo4 100kW Stage V
- Deutz Stage V

### Driving cab

- FOPS certification reversible driving position

### Carrier chassis

- 4 wheel drive
- 4 wheel steering
- axles planetary type, Dana Spicer
- 2 speeds
  - 1<sup>st</sup> gear max 8 km/h
  - 2<sup>nd</sup> gear max 26 km/h

### Uniflux H1.0 dosing system

- Peristaltic pump with hydraulic drive ASP25
- Electronic management

### Concrete pump

- Diesel and Electric operated
- Proportional flow regulation
- Electric vibrator fitted to the grid

### Proportional radio-remote control

- n° 2 transmitters
- Safety cable

### Washing system

- High pressure water pump, 50 l/min - 50 bar
- Hydraulic drive
- Nozzle and 10 m of pipe
- Water tank, 600 l
- Handpump for concrete anti-adhesion protection

### Automatic lubrication for

- S valve
- Pumping group mixer
- Boom sliding turret and boom double trust block
- Electric motor ABB 55kW IE3

### Electrical System Carrier

- 24 V
- Battery 2 x 120 Ah
- Alternator 55 A
- Front lights 2 x 55 W
- Rear lights 2 x 55 W

### Shotcreting operations

- Working lights N 6 x 45W-4800 lumen xenon
- Working lights on hopper N 1 x 70W

### Nozzle brush movement

### One colour painting, RAL 2000

## Main options

- Compressor (75 kW, 11.500 l/min, max 7,5 bar)
- Additives heating system
- ATEX configuration
- Cold climate oil
- Low flammable oil
- Fire suppression system on Diesel engine compartment
- ROPS certification
- Peristaltic pump with hydraulic drive ASP15 or peristaltic pump with hydraulic drive ASP32

The use of the product must not exceed 2000 metres in elevation above sea level. Above this elevation the correct operation of the system is impaired and this case has to be previously notified to CIFA.

## Mobile Concrete Sprayer

Shotcrete Boom	MAMBA
Pumping Unit	PAS 307
Shotcreting	Diesel/Electric
Chassis	2 axles

## Technical data

PUMPING UNIT TECHNICAL DATA		
MODEL		PAS 307
Theoretical output (Min ÷ Max)	m <sup>3</sup> /h	5 ÷ 30
Max. pressure on concrete	bar	65
Max. number of cycles per minute	n°	16
Concrete cylinders (diam. x stroke)	mm	200X1000
Hopper capacity	l	300
Installed power (electric - diesel)	kW	55 - 65
PLACING BOOM TECHNICAL DATA		
MODEL		MAMBA
Turret rotation angle		± 180°
1 <sup>st</sup> section lifting angle		+65° / -25°
1 <sup>st</sup> section telescopic extension		2
2 <sup>nd</sup> section lifting angle		+33° / -61°
2 <sup>nd</sup> rotary table rotation angle		+173° / -90°
2 <sup>nd</sup> section telescopic extension	m	2
Longitudinal nozzle rotation		180°
Transversal nozzle rotation		± 90°
Boom longitudinal sliding stroke	m	3,7 / 2.5*
* if the optional "air compressor" is chosen		
DOSING SYSTEM TECHNICAL DATA		
MODEL		Uniflux H1
Theoretical output (Min ÷ Max)	l/min	1 ÷ 21
Max pressure	bar	13
Accelerator tanks	/	2 X 1000
TRUCK CHASSIS TECHNICAL DATA		
MODEL		Shottruck 2
Power	kW@rpm	100@2300 (Stage V)
Turning circle	m	5,2
Wheelbase	m	3,7
Coupling angle		16,5°
Outlet angle		18,5°
Truck tyres		16x24
Net Weight (dry)	Kg	16000 / 17500**
Max. Weight	Kg	20000

Technical data and characteristics subject to modifications without notice